

In electrical maintenance works, in order to cope with safety standards, it becomes necessary to identify de-energized cables unambiguously prior to its manipulation.

Cutting the wrong cable may result in the following consequences:

- personnel live threat
- power supply failure

ARIADNA CI cable identifier is an advanced, yet simple to operate, digital tool.

It helps users to easily identify **de-energized** and **energized MV&LV** cables electrical cables among multiple conductors, in trenches, manholes, panels, aerial/underground conversions, etc.



CI-TX



CI-RX

Main Features:

- Identifies:
 - energized MV cables
 - energized LV cables
 - de-energized MV and LV cables
- Works with:
 - Single phase conductors (shielded or unshielded)
 - Three phase or 3 phase + neutral conductor
- Signal injection by:
 - Direct connection to cables
 - Signal induction through toroidal clamp (optional)
- Detects active signal's Amplitude and Polarity
- Maximum cable length > 10km (direct connection)
- Rechargeable Li-ion battery on transmitter (CI-TX):
- >24h at level 2 (up to 4) of transmission power

➤ Energized MV cable identification

It works by sinking energy from a live network, by connecting a load at the LV side of an MV/LV transformer, and detecting the current that is produced at the MV side of the transformer.

The CI-TX unit acts as the signal transmitter that sinks energy from the electric grid, producing coded current pulses, and the CI-RX unit as the digitally tuned receiver that detects them.

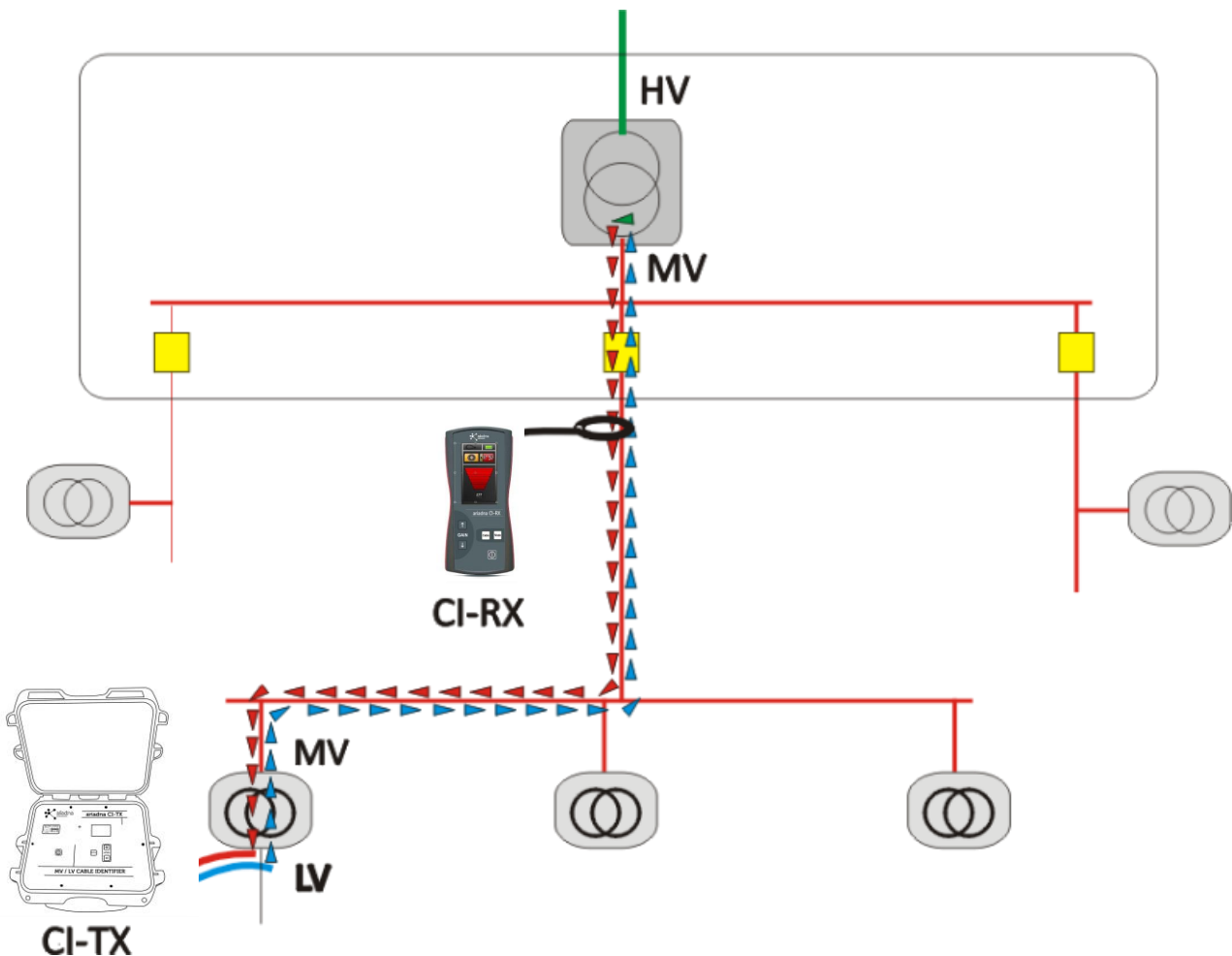

➤ Energized LV cable identification

In a similar way to MV live cable identification, it is possible to identify LV energized cables by sinking current from the network.

CI-TX transmitter is connected at the end side of the LV cable to be identified. When turned on, it starts to sink current pulses from the network, and these pulses flow from the point of injection to the LV transformer that feeds it.

With the CI-RX unit it is possible to identify LV cable path in any accessible places, like manholes, busbars, etc.

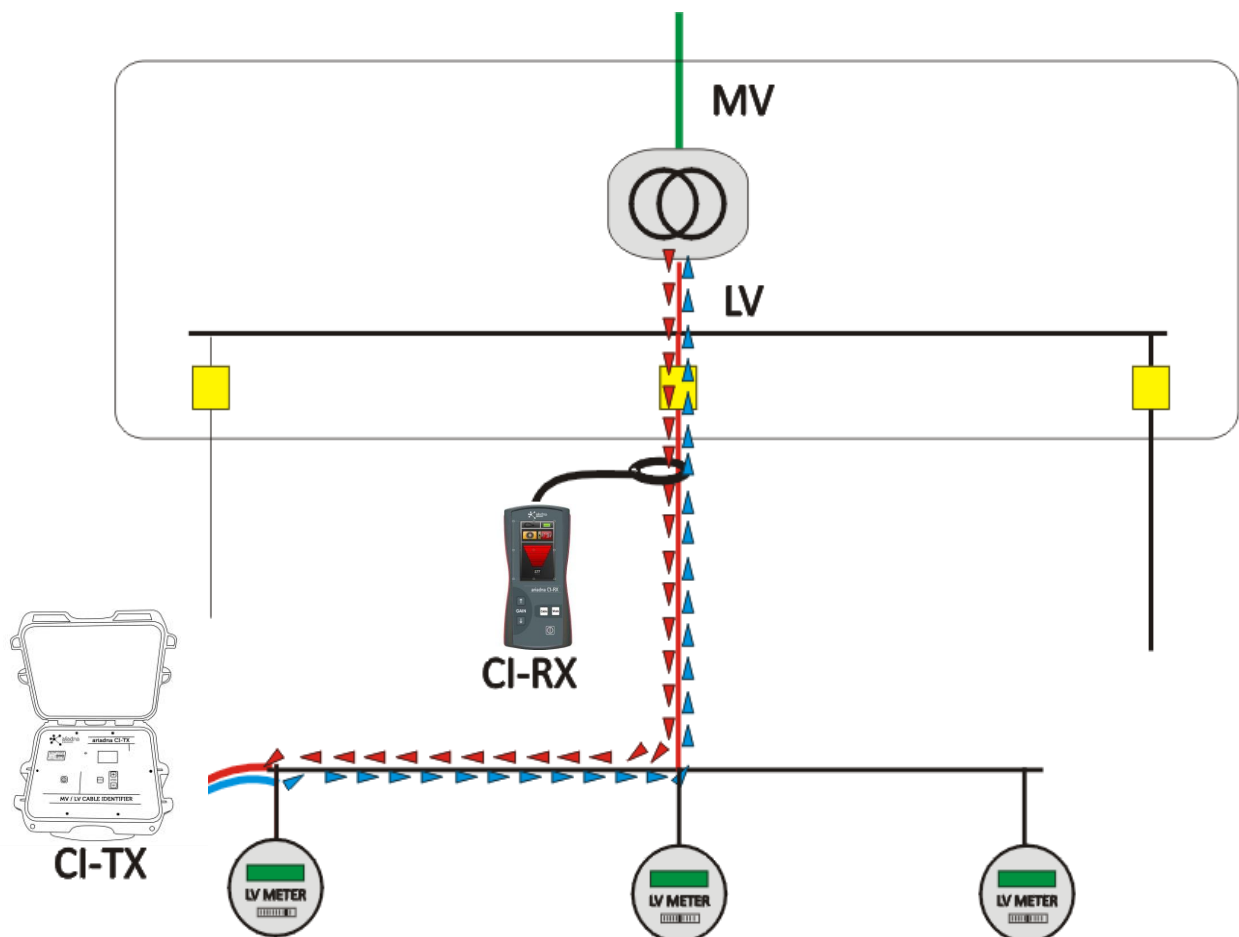

➤ De-energized MV & LV cable identification

Through polarized frequency signal injection and detection, it is possible to positively identify de-energized cables.

Unlike live cable identification, the needed energy for generating identification signals come from CI-TX's rechargeable li-ion battery, instead of coming from the grid.

Two ways are available for injecting signals on cables, through direct connection or by using a toroidal inductive clamp.

Afterwards cables are identified by measuring produced signal's amplitude and polarity.

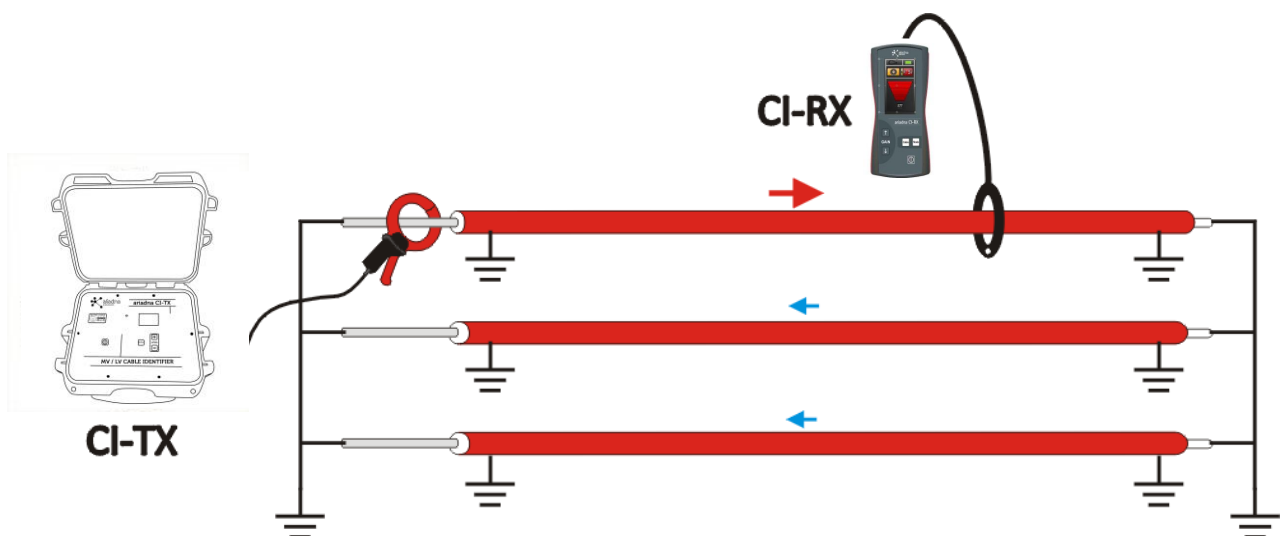

* Technical Specs

CI-TX		CI-RX	
Size	315x255x150 mm	Size	120 x 220 x 65 mm
Weight	3 kg	Weight	0.75 kg
Protection degree	IP65	Protection degree	IP54
Display	Monochrome 160x100	Display	Color TFT 240x400
Rechargeable battery	8.4V 6.6Ah Li-ion	Batteries	4x1,5V AA
Battery charger input	100-240VAC 50/60Hz	Operating Temperature	-10°C a 55°C
Battery charger output	12VDC 2A		
Car lighter charger	Yes		
Operating Temperature	-10°C a 55°C		
Fuse at the end of the mains leads	6.3x32 mm 10A 500V 50KA type F		

<u>Energized Cables</u>			
Signal type	Current pulses	Active signal analysis (from TX)	amplitude and polarity
Injected signal amplitude	160/80A peak	Passive current measurement	50/60Hz RMS
Max. network voltage	440Vac	Max. network current (50/60Hz)	1800A RMS (Rog)
Operation time	>24h	Maximum cable length	>10km

<u>De-energized cables</u>			
Signal type	current frequency	Active signal analysis (from TX)	amplitude and polarity
Active signal power	10W	Maximum cable length	>20km
Operation time (level 2)	>24h	Max. loop resistance	1000 Ω

* Specifications subject to change without notice

Ariadna CI detects medium and low-voltage cables (energized or de-energized), and complies with the following safety standards:

- Electromagnetic compatibility: EN 61000-6-3, EN 61000-6-2.
- Electrical safety: EN 61010-1 CAT IV 300V.
Protection against electric shock. Class II.

Power cable identification and location solutions